

Platforms

Design by Roger Webb Associates

Product Brochure 2017

Platforms

Simple, Flexible & Modular Two-Tiered Auditorium Seating

Education focused auditorium seating available in three modules: 1350mm straight, 1540mm straight and 1155mm corner unit. Now with in-built under seat storage as standard. Available with seat and scatter cushions for additional comfort, power options for connectivity, protective floor covering and casters for mobility.





SCIENCE

HEWLETT-PACKARD

Platforms

Modular Specifications

Product Information

- 3 straight or corner modules available
- 16mm birch veneer plywood construction
- Supplied partly assembled with completely tool-free assembly of modules and configurations
- Convenient carry handles enable modules to be reconfigured easily and are utilised to connect modules together using a dedicated bracket and thumb-turn fixings
- In-built under seat storage

Options

- Seat cushions available in all fabric groups
- Neutral grey Interface carpet or Bolon vinyl floor covering available on the first tier behind upholstery to resist marking and improve grip
- Casters available for easy mobility
- Power units available

Dimensions (mm)

SPL1

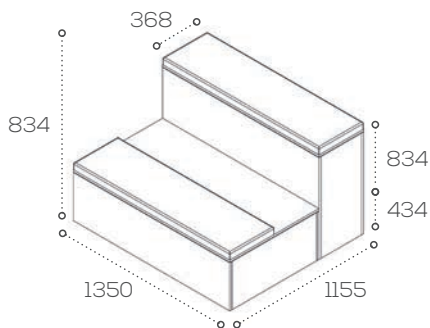

Weight: 74kg

SPL2

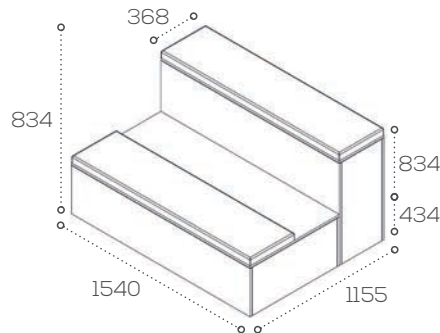

Weight: 82kg

SPL3

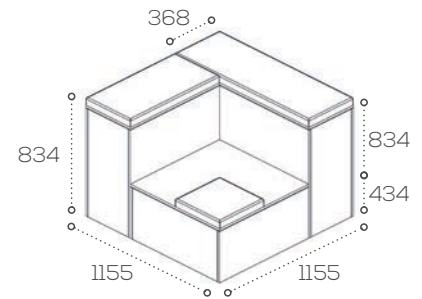

Weight: 85kg



Platforms

Configurations

Dimensions (mm)

L-shape

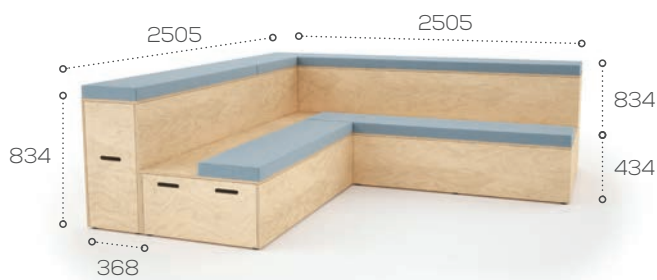

Straight

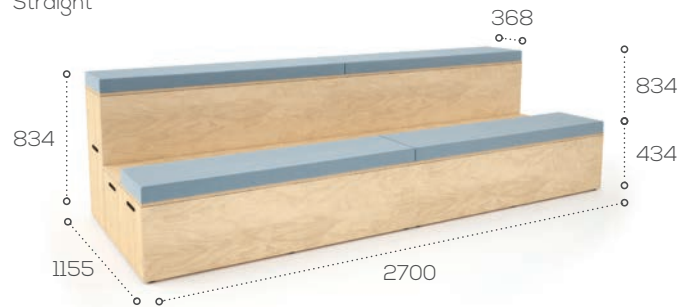

Asymmetric L-shape

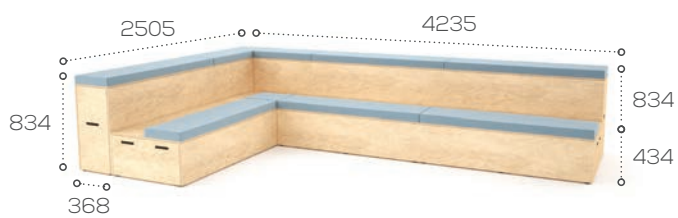

U-shape



Head Office & Showroom

Dogley Mills,
Penistone Road,
Huddersfield,
West Yorkshire,
HD8 0LE

Tel: 01484 600 100
sales@connection.uk.com

London Showroom

31 Great Sutton Street,
Clerkenwell,
London,
EC1V 0NA

Tel: 020 7253 9877
www.connection.uk.com

Manchester Showroom

The Old Law Library,
Kennedy Street,
Manchester,
M2 4BY

